

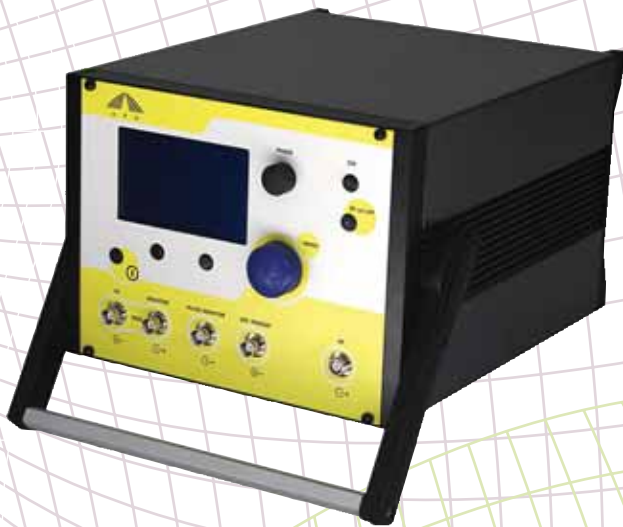

A P E

# CAVITY DUMPER KIT



Cavity Dumping is a method of generating powerful laser pulses by diverting part of the energy stored inside a closed resonant laser cavity. This way the peak pulse power exceeds the cw- or modelocked output of the laser many times. The repetition rate is adjustable from a single shot to some MHz.

The APE Cavity Dumper is constructed as an upgrade set for different lasers, e.g. Ti:Sapphire, nobel gas ion and dye systems. It can be used both for high power generation in cw- lasers and for pulse enhancement/ repetition rate reduction of modelocked systems.

The heart of the driver electronics is a low jitter clock divider with synchronization input that drives a fine delay stage and an RF power amplifier to generate the output pulses. A precise phase shifter allows for optimization with respect to diffraction efficiency and contrast ratio, especially in double pass operation.

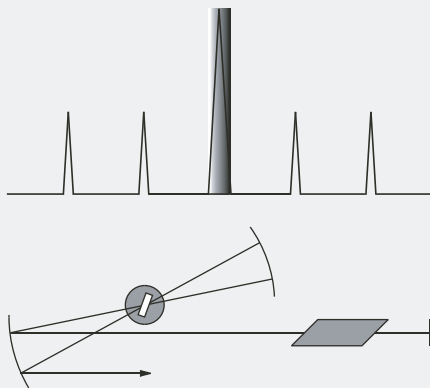

Generation of powerful laser pulses

Fast risetimes

Tunable phase shift

Driver unit and Bragg cell

Laser Diagnostics

Spectral Analysis

Acousto-optics

Non-Linear Optics

Accessories

**Your Partner in Ultrafast**

# CAVITY DUMPER KIT

## SPECIFICATIONS

Modulator material	fused silica
Wavelength range	500 ... 1000 nm <sup>1)</sup>
Diffraction efficiency	typ. > 50 % <sup>2)</sup>
Seed frequency	70 ... 85 MHz (to be specified to 1MHz accuracy)
Output repetition rate	single shot ... 10 MHz externally triggered internal division ratio 1 : 20 ... 1 : 5000 of seed frequency (1 : 2 ... 1 : 260000 optional)
Carrier frequency	350 ... 425 MHz <sup>3)</sup>
Electrical rise time	2 ns
Jitter	< 50 ps
Phase shift	> 180°

1) others optional

2) measured at 800nm, 4MHz, single pass; varying with wavelength and repetition rate

3) synchronized to seed frequency

## DIMENSIONS

Control Electronics (W*L*H in mm)	267 x 312 x 180
-----------------------------------	-----------------

Optics Unit:

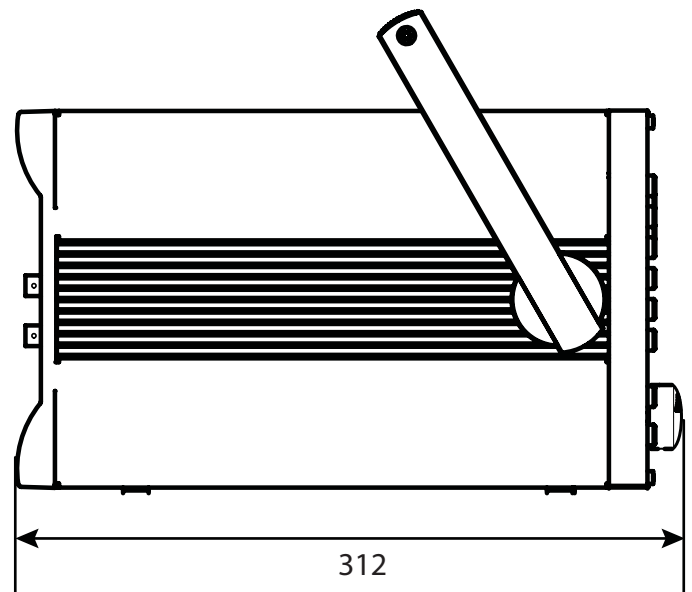
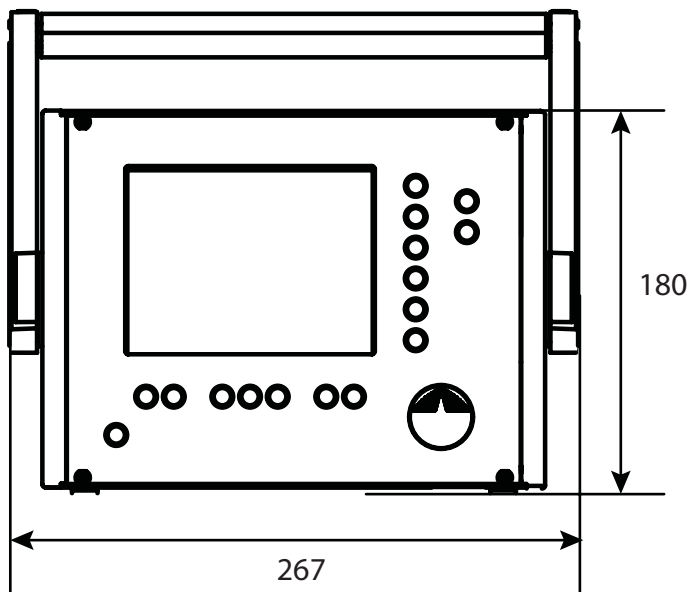

Distributors  
for distributors please check our website