

ScanDelay

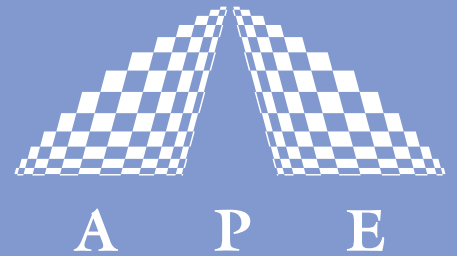

OPTICAL DELAY LINE SERIES

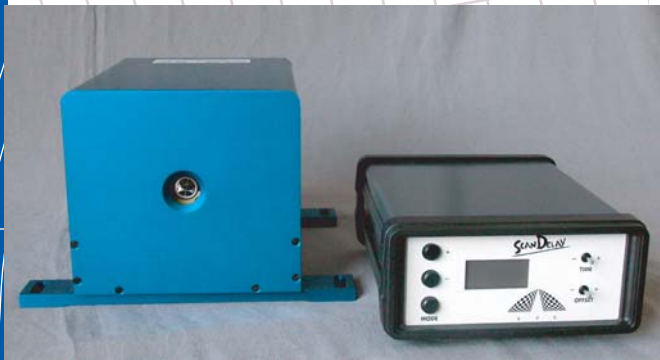

ScanDelay is a device for translation and positioning of optical elements, e.g. in interferometers, pump and probe configurations, correlators or fast scan modules.

The heart of the APE optical delay lines **ScanDelay** is a special linear translation stage that is supplied together with an appropriate control and drive electronics. The linear drives have been designed especially for optical applications. They combine low moved weight with compactness and reach high precision and resolution. They are simply controlled by an electrical signal. Because of their spring bearings the movement is frictionless.

So **ScanDelay** is capable of generating fast wide scans as well as smallest delays without any stick-slip effects. The actual position is measured online by an analog photoelectrical system to get a linear calibrated scaling with high resolution and a wide dynamic range.

The control electronics contains the motor driver and a quartz stabilized signal syntheser. The closed position control loop always forces the scanner to follow the signal voltage. With the advanced controller both fast and slow scan movements can be generated.

Special linear drive with closed loop motion control

High resolution because of spring bearings

Compact construction

Linear and calibrated scaling due to position measurement

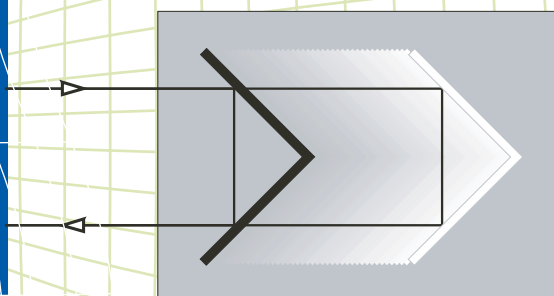

Ultrafast Pulse Diagnostics

Spectral Analysis

Acoustooptics

Pulse Management

Wavelength Conversion

Your Partner in Ultrafast

SCANDELAY

SPECIFICATIONS

Version	15	50	150
Max. scan range	15 ps (± 1.125 mm)	50 ps (± 3.75 mm)	150 ps (± 11.25 mm)
Scan modes			
Slow		0.5 ... 0.01 Hz	
Fast		0.1 ... 20 Hz	0.1 ... 10 Hz ¹⁾
Position output signal	± 5 V / 15 ps ²⁾	± 5 V / 50 ps ²⁾	± 5 V / 150 ps ²⁾
External control voltage		± 10 V / 300 Ω ³⁾	
Linearity of position signal		< 0.5 %	
Interface		RS232	

1) for 150 only: optional up to 20 Hz with reduced amplitude

2) *10, *100 switchable

3) scan amplitude varies with scan frequency

OPTICS (high precision retroreflector)

clear aperture	1"	1/2"	1/2"
coating	protected Ag (other coatings on request)		

DIMENSIONS (in mm)

ScanDelay 15/50

ScanDelay 150

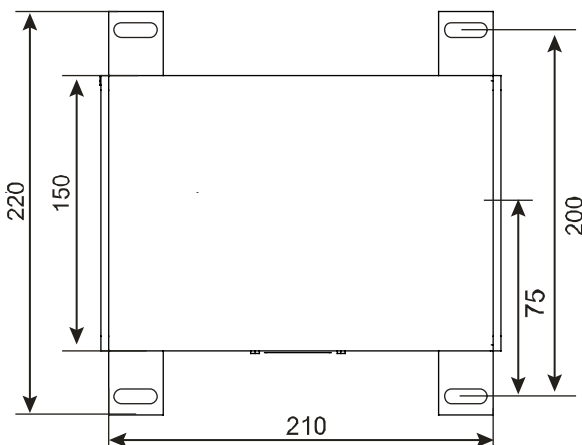
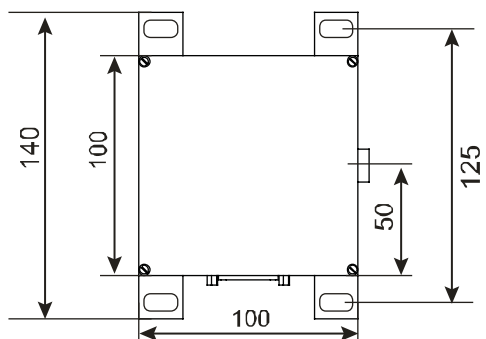
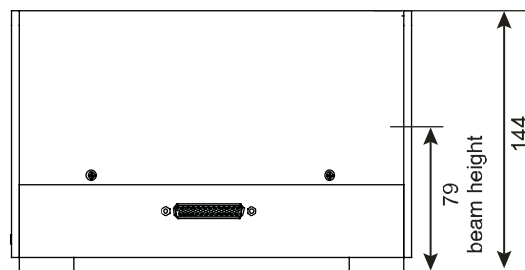
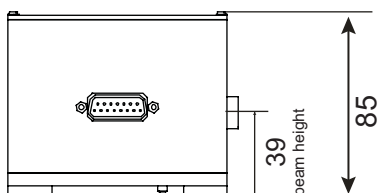

Distributors
see APE website