

LEVANTE

EMERALD

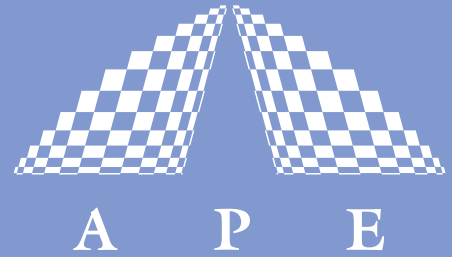

PICOSECOND-OPO

The Ultimate Light Source for CARS Microscopy



Using a frequency doubled Nd:YVO-Laser (532 nm) as pump source this OPO provides the user with an attractive low cost solution for generating picosecond pulses tuneable over a wide range with high output energy in the NIR from < 680 nm ... >2450 nm. Thereby the Levante Emerald substitutes "long pulse picosecond" Ti:Sapphire laser plus synchronously pumped OPO

The output pulses are nearly transform limited, show high beam quality and great pointing stability at the same time. The system covers a wide wavelength range in the NIR; it is easy to use, fast and PC controllable.

The perfect spatial and temporal overlap of signal and idler beam, which are outcoupled on one single beam axis (collinear), constitutes a completely new quality. The difference in energy between the two wavelengths is continuously tuneable. These features make the Levante Emerald the ideal light source for multicolor excitation experiments such as CARS microscopy (Coherent anti-Stokes Raman scattering). Alternatively, signal and idler are led to exit at different output ports by using the included beam separator

Picosecond Pulses for CARS and RAMAN techniques

Two-Colour Output

Perfect Pulse Synchronization

Levante Emerald / typical signal power @ 4.5W pump

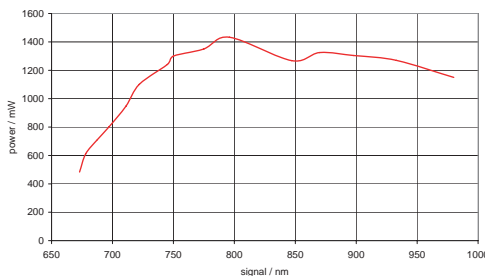

Levante Emerald typical idler power @ 4.5W pump

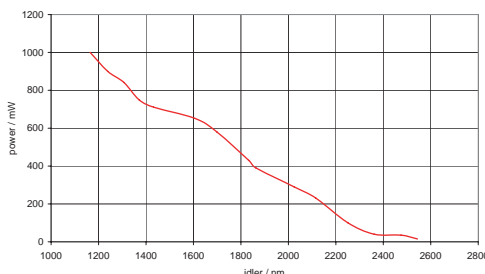

Signal and Idler Power Curves
typ. @ 4.5 W pump

Ultrafast Pulse Diagnostics

Wavelength Conversion

Pulse Management

Acoustooptics

Your Partner in Ultrafast

TECHNICAL DATA

	Signal	Idler
Tuning ranges	690 (typ. <680) ... 990 nm	1150 ... 2300 nm (typ. >2450)
Output power	> 0,75 W (750 - 990 nm)	+ > 0,6 W (1150 - 1350 nm)
	@ 532 nm, 4 W pump	
$\Delta\nu$ Signal-Idler	1350 ... 10000 cm^{-1}	
$\Delta\nu$ Signal - 1064 nm	< 700 ... >5000 cm^{-1}	
Pulse length	~ 5 - 6 ps	
Spectral bandwidth (Signal/typical)	0,3 - 0,4 nm	
Time bandwidth product	typ. 0,6	
Pulse repetition rate	76 MHz (others on request)	
Interface	RS 232	
M^2	< 1,1 (typ. 1,05)	< 1,2 (typ. 1,1)
Polarization	horizontal (signal + idler)	

The APE Levante Emerald is delivered with an integrated spectrometer and removeable signal/idler beam separator

Also available for 1064 nm pump: **Levante IR**

DIMENSIONS (W*L*H in mm)

Control Electronics 267 x 312 x 180

Optics Unit:

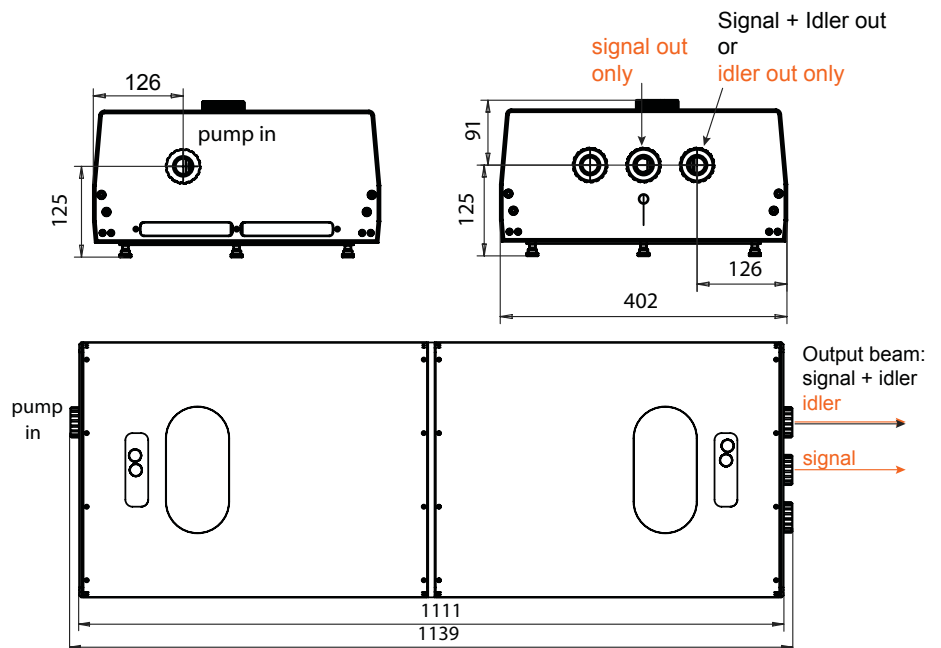

• optional beam separation by using included beam separator